

UNIVERSITY OF CAMBRIDGE INTERNATIONAL EXAMINATIONS
General Certificate of Education Advanced Level

FURTHER MATHEMATICS

9231/02

Paper 2

October/November 2006

3 hours

Additional Materials: Answer Booklet/Paper
Graph paper
List of Formulae (MF10)

READ THESE INSTRUCTIONS FIRST

If you have been given an Answer Booklet, follow the instructions on the front cover of the Booklet.
Write your Centre number, candidate number and name on all the work you hand in.
Write in dark blue or black pen on both sides of the paper.
You may use a soft pencil for any diagrams or graphs.
Do not use staples, paper clips, highlighters, glue or correction fluid.

Answer **all** the questions.

Give non-exact numerical answers correct to 3 significant figures, or 1 decimal place in the case of angles in degrees, unless a different level of accuracy is specified in the question.

Where a numerical value is necessary, take the acceleration due to gravity to be 10 m s^{-2} .

The use of a calculator is expected, where appropriate.

Results obtained solely from a graphic calculator, without supporting working or reasoning, will not receive credit.

You are reminded of the need for clear presentation in your answers.

The number of marks is given in brackets [] at the end of each question or part question.

At the end of the examination, fasten all your work securely together.

This document consists of **6** printed pages and **2** blank pages.



- 1 A uniform rod AB , of length $2a$ and mass m , has a particle of mass $\frac{1}{2}m$ attached to B . The rod is smoothly hinged at A to a fixed point and can rotate without resistance in a vertical plane. It is released from rest with AB horizontal. Find, in terms of a and g , the angular acceleration of the rod when it has rotated through an angle of $\frac{1}{3}\pi$. [5]
- 2 A light elastic string AB , of natural length 0.5 m and modulus of elasticity 12 N, has a particle of mass 0.3 kg attached to B . The end A is attached to a fixed point at a distance of 0.7 m above a horizontal table. The coefficient of restitution between the particle and the table is e . The particle is released from rest at A , hits the table and rebounds to a height of 0.22 m above the table. Find the value of e , assuming that there is no air resistance. [7]
- 3

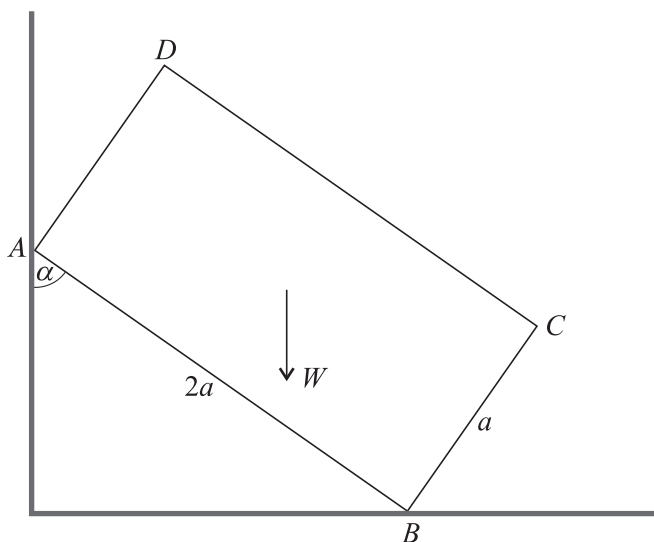

The diagram shows a cross-section $ABCD$ of a uniform rectangular block of weight W . The lengths of AB and BC are $2a$ and a respectively. The edge through A rests against a smooth vertical wall and the edge through B rests on a rough horizontal floor. The coefficient of friction between the block and the floor is μ . The block is in equilibrium with AB inclined at an angle α to the vertical. Show that the wall exerts a force of magnitude $\frac{1}{4}(2 \tan \alpha - 1)W$ on the block. [4]

Show also that $\tan^{-1}\left(\frac{1}{2}\right) \leq \alpha \leq \tan^{-1}\left(\frac{1}{2} + 2\mu\right)$. [5]

4

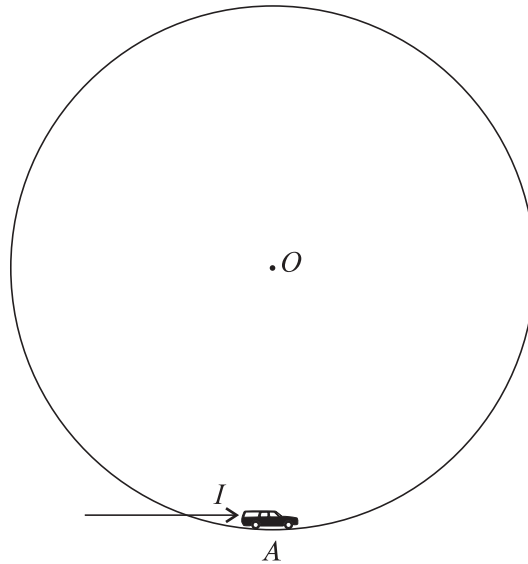

The diagram shows a toy car of mass m which can move freely on a circular track of radius a and centre O . The track is fixed with its plane vertical. The car is given a horizontal impulse of magnitude I when it is at rest at the lowest point A of the track. The car may be modelled as a particle moving without resistance. Show that the force that the track exerts on the car when the radius to the car makes an angle θ with OA has magnitude

$$mg(3 \cos \theta - 2) + \frac{I^2}{ma}. \quad [6]$$

Find the set of values of I for which the car does not lose contact with the track. [4]

- 5 A particle P of mass m is attached to one end of a light string of natural length $2a$ and modulus of elasticity $6mg$. The other end of the string is attached to a fixed point A on a smooth horizontal table. A second light string, of natural length $3a$ and modulus of elasticity $3mg$, has one end attached to P . The other end of this string is attached to a fixed point B on the table, where $AB = 6a$. The particle moves in the straight line AB . Show that if both strings remain taut throughout the entire motion then the motion of P is simple harmonic motion of period $\pi\sqrt{\left(\frac{a}{g}\right)}$. [5]

At time $t = 0$ the particle is released from rest at the point R on AB , where $AR = l$.

- (i) Find the conditions on l which ensure that both strings remain taut throughout the entire motion. [2]
- (ii) Given that R is the mid-point of AB , find, in terms of a and g ,
- (a) the speed of P when the string AP first becomes slack,
- (b) the value of t when this occurs. [5]

- 6 The sugar content of a brand of cough medicine was measured in a sample of five bottles. The results as percentages by weight were

52.3, 55.7, 51.4, 56.2, 54.0.

These may be considered to be a random sample from a normal distribution with mean μ .

- (i) Obtain a 95% confidence interval for μ . [5]

A further bottle is analysed. The combined sample of six results gives a smaller variance estimate than that used in part (i).

- (ii) State, giving your reasons, whether a 95% confidence interval for μ based on the six results will be wider or narrower than the interval found in part (i). [2]

- 7 Tom and Brad shoot arrows at a target. For each shot the probability that the arrow hits the bull's-eye is 0.2, independently of all other shots.

- (i) Find the probability that Tom takes more than 10 shots to hit the bull's-eye. [2]

- (ii) Find the probability that Tom and Brad take the same number of shots to hit the bull's-eye. [3]

- (iii) Find the probability that Tom takes more shots than Brad to hit the bull's-eye. [2]

- 8 Two types of cloth, Type *A* and Type *B*, were tested for flame-resistance. 45 pieces of Type *A* and 48 pieces of Type *B*, of equal size, were selected at random. Each was set alight in the same way and the times to extinction of the flames were measured. The results, x_A minutes and x_B minutes, are summarised by

$$\Sigma x_A = 276.5, \quad \Sigma x_A^2 = 1823.0, \quad \Sigma x_B = 267.8, \quad \Sigma x_B^2 = 1649.2.$$

Test, at the 2% significance level, whether there is a difference in the mean times to extinction for the two types of cloth. [8]

Explain, in the context of the question, the meaning of 'at the 2% significance level'. [1]

- 9 The number of times that machines break down each week in a weaving mill were recorded for 50 weeks. The results are summarised in the following table.

Number of weekly breakdowns (x)	0	1	2	3	4	5	≥ 6
Number of weeks	8	6	16	12	3	5	0

Find the mean and variance of the number of weekly breakdowns in the sample. State whether their values support the suggestion that the number of weekly breakdowns has a Poisson distribution. [3]

The following table includes the corresponding expected values, correct to 2 decimal places, using an appropriate Poisson distribution.

Number of weekly breakdowns (x)	0	1	2	3	4	5	≥ 6
Number of weeks	8	6	16	12	3	5	0
Expected value	5.43	12.06	13.38	9.90	5.50	2.44	1.29

Show that the expected value for $x = 3$ is correct. [2]

Test, at the 10% significance level, the goodness of fit of a Poisson distribution to the data. [5]

- 10 For a random sample of 12 observations of pairs of values (x, y), the equation of the regression line of y on x is $y = 4.82 - 2.25x$. The sum of the 12 values of x is 20.64 and the product moment correlation coefficient for the sample is -0.3 .

(i) Find the sum of the 12 values of y . [2]

(ii) Find the equation of the regression line of x on y . [4]

(iii) Test, at the 5% significance level, whether there is evidence of negative correlation between the variables. [2]

(iv) Find the estimated value of y when $x = 2.8$ and comment on the reliability of this estimate. [2]

11 Answer only **one** of the following two alternatives.

EITHER

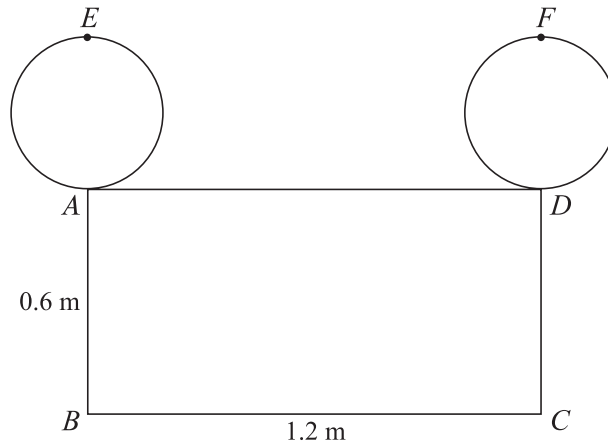

A sign is formed from two uniform discs, each of mass 0.25 kg and radius 0.2 m, rigidly fixed to a uniform rectangular lamina $ABCD$ at A and D . The disc attached at A has diameter AE and BAE is a straight line. The disc attached at D has diameter DF and CDF is a straight line. The discs are in the same plane as $ABCD$. The mass of the rectangular lamina is M kg, and $AB = 0.6$ m, $BC = 1.2$ m. The sign is hung from smooth supports at E and F with AD horizontal (see diagram). Show that the moment of inertia of the sign about an axis through F perpendicular to $ABCD$ is $(0.39 + M)$ kg m².

[8]

The support at E breaks and the sign rotates freely under gravity, in a vertical plane, about the axis through F . Assuming that AD becomes vertical in the subsequent motion when the sign is rotating with angular speed ω rad s⁻¹, show that

$$\omega^2 = \frac{2(2 - M)}{0.39 + M}. \quad [4]$$

What happens if $M > 2$?

[2]

OR

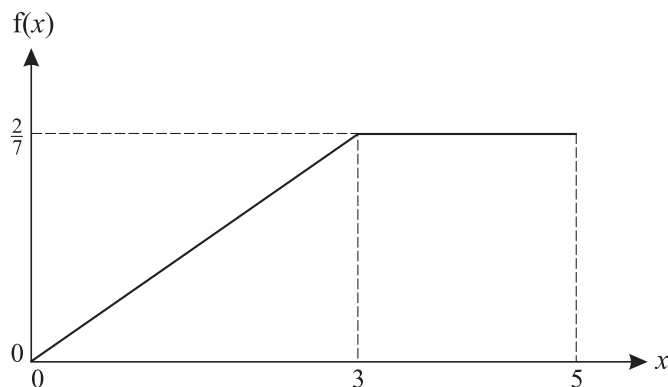

The continuous random variable X takes values in the interval $0 \leq x \leq 5$ only. On this interval the graph of its probability density function, f , consists of the two straight line segments shown in the diagram. Find the distribution function of X .

[4]

The random variable Y is given by $Y = \sqrt{5 - X}$. Find the distribution function of Y .

[6]

Find $P(Y < 2X)$.

[4]

BLANK PAGE

BLANK PAGE

Permission to reproduce items where third-party owned material protected by copyright is included has been sought and cleared where possible. Every reasonable effort has been made by the publisher (UCLES) to trace copyright holders, but if any items requiring clearance have unwittingly been included, the publisher will be pleased to make amends at the earliest possible opportunity.

University of Cambridge International Examinations is part of the University of Cambridge Local Examinations Syndicate (UCLES), which is itself a department of the University of Cambridge.